

JUKI®

No. 0002-00

1975-2

BE5200SOPJA

model **LUH-520**

二本針本縫総合送りミシン

Two-needle, Unison Feed Lockstitch
Industrial Sewing Machine

PARTS BOOK

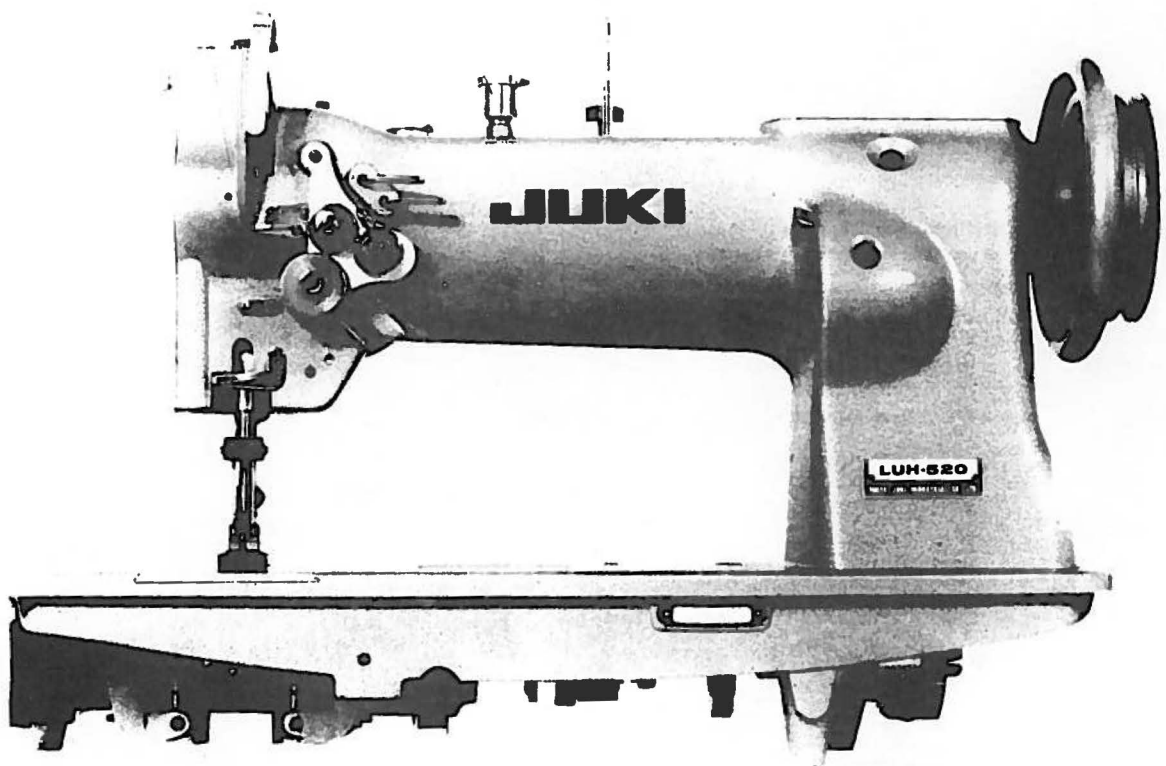

TOKYO JUKI INDUSTRIAL CO., LTD.

HOW TO MAKE USE OF THIS PARTS BOOK

1. This parts book is divided, as a basic principle, into various sections according to the functions of respective parts.
2. The figures on the illustrations indicate the corresponding numbers (Ref. No.) shown by the Index.
3. Explanation of codes
 - 1) ① The part with ☆ mark in the "Note" column means this part is changed, added, obsoleted or revised.
 - ② For the parts with the codes ◊ and ◆, in "Note" column, please refer to explanation under separate sheet or under the sketch.
 - 2) The codes in the "E.C." (Engineering Change) column indicate following changes:
 - ① A,1/75 Added in January, 1975
 - ② D,1/75 Obsoleted from January, 1975
(In this case, only when substitute part can be used intact, this part number will be shown in the "品名" column of Japanese "Description").
 - ③ M,1/75 The amount required (Amt. Req.) is changed from January, 1975
(In this case, the figure in the "Amt. Req." column shows the changed amount figure.)
 - ④ C,1/75 Error in the part number was found in January, 1975, so revised to correct part number.
(In this case, correct part number is written in the "Part No." column and the wrong part number is written down in the "品名" column.

(Example)

| Ref. No. | Note | Part No. | Description | E.C. | 品名 | Amt. Req. |
|----------|------|----------------------|-------------|--------|----------------------|-----------|
| | 注記 | 品番 | | 変更年月 | | 数量 |
| 1 | ☆ | <u>B1234-123-000</u> | Needle bar | C,3/75 | <u>B1234-723-000</u> | 1 |
| | | ↑ | | | ↑ | |
| | | Correct No. | | | Wrong No. | |

Note: Consequently, in case C code is entered in the "E.C." column, the part number in the "品名" column is wrong, so please do not place your order with this wrong part number

- 3) The codes on the "Amt. Req." column indicate the following:
 - ① 2 means required amount, namely 2 ea.
 - ② 2.0 means required length, namely 2 meter (in this case the unit is meter).
 - ③ — Part which was obsoleted from this parts list.
 - ④ 1 This is assembly part and is written down in English as "asm." and as "(組)", "クミ" in Japanese.

(1) }
 (2) } means parts which construct assembly unit and the part just above this is shown the assembly of these parts.
 (3) }

(Example)

| Ref. No. | Note | Part No. | Description | E.C. | 品名 | Amt. Req. |
|----------|------|---------------|-------------|------|---------|-----------|
| | 注記 | 品番 | | 変更年月 | | 数量 |
| 10 | | B1234-012-0A0 | Frame asm. | | フレーム(組) | 1 |
| 11 | | B1123-012-000 | Frame | | フレーム | (1) |
| 12 | | SS-7111510-SP | Screw | | 止ネジ | (2) |

4. Examples of interchangeability parts

1) In case of changing interchangeable parts

| Ref. No. | Note | Part No. | Description | E.C. | 品名 | Amt. Req. |
|----------|------|----------------|-------------|---------|------------|-----------|
| | 注記 | 品番 | | 変更年月 | | 数量 |
| 1 | ☆ | B1301-400-000 | Needle bar | D,12/74 | Needle bar | — |
| 1-1 | ☆ | B1301-400-000A | Needle bar | A,12/74 | Needle bar | 1 |

2) In case of changing no-interchangeable parts

| Ref. No. | Note | Part No. | Description | E.C. | 品名 | Amt. Req. |
|----------|------|----------------------|-------------|---------|----------------------|-----------|
| | 注記 | 品番 | | 変更年月 | | 数量 |
| 1 | ☆ | <u>B1234-200-000</u> | Frame cover | D,12/74 | <u>B1234-300-000</u> | |
| 1-1 | ☆ | B1234-300-000 | Frame cover | A,12/74 | フレームカバー | 1 |

(In this case, order by the new part number)

パーツリストの見方

- このパーツリストは、原則として、機構別に分類された各項目からなりたっております。
- 図に示された部品の品番は、図にふられているNo(Ref.No.)に対応するIndexによって、その品番がわかります。
- 記号の説明
 - ① “注記”欄に☆印がついた部品は、変更、追加、削除又は訂正された部品を意味します。
 - ② “注記”欄に◇、◆印がついた部品は、“注記”の説明を参照して下さい。
 - ③ “変更年月”欄の記号は、それぞれ次の様な内容を意味しております。
 - ① A, 10/74.....1974年10月より追加された。
 - ② D, 1/75.....1975年1月より削除された。
 この場合、代替部品がそのまま使用できる場合に限り、その品番を和文品名欄に表示します。
 - ④ M, 2/75.....1975年2月より数量が変更になった。
この場合数量欄の数字は変更後の数量が表示してあります。
 - ⑤ C, 3/75.....1975年3月に品番のミスが判明した為、正しい品番に訂正された。
この場合は品番欄には正しい品番が記入され、間違いの品番は和文品名欄に記入されます。

[例]

| Ref. No. | Note 注記 | Part No. 品番 | Description | E.C. 変更年月 | 品名 | Amt. Req. 数量 |
|----------|------------|-------------------------------|-------------|--------------|----------------------------------|--------------------|
| 1 | ☆ | B1234-123-000 ↑ [正しい品番] | Needle bar | C, 3/75 | B1234-723-000 ↑ [間違っていた品番] | 1 |

☆注、 [従って図案欄にC記号の入っている場合は、和文品名欄の品番は間違っている品番を意味しておりますので、この品番で部品を注文しないで下さい。]

3) 数量欄の記号は、それぞれ次の様な内容を意味しております。

- 数量
- ① 2必要な数量、即ち2個を意味します。
 - ② 2.0必要な長さ、即ち2メートルを意味します。(この場合単位はメートルです)
 - ③ —このパーツリストから削除された部品です。
 - ④ 1組部品で品名欄に英文で“asm.”、和文で“クミ”又は(組)と表示してあります。
 - (1)
 - (2)
 - (1)
 組部品を構成している子部品を意味し、そのすぐ上にある部品が組部品です。

[例]

| Ref. No. | Note 注記 | Part No. 品番 | Description | E.C. 変更年月 | 品名 | Amt. Req. 数量 |
|----------|------------|----------------|-------------|--------------|---------|--------------------|
| 10 | | B1234-012-0A0 | Frame asm. | | フレーム クミ | 1 |
| 11 | | B1234-012-000 | Frame | | フレーム | (1) |
| 12 | | SS-7111510-SP | Screw | | トメボジ | (2) |

4. 表示例

- 1) 互換性がない部品の変更の場合

| Ref. No. | Note 注記 | Part No. 品番 | Description | E.C. 変更年月 | 品名 | Amt. Req. 数量 |
|----------|------------|-----------------|-------------|--------------|------|--------------------|
| 1 | ☆ | B1301-400-000 | Needle bar | D, 12/74 | ハリボウ | — |
| 1-1 | ☆ | B1301-400-000-A | Needle bar | A, 12/74 | ハリボウ | 1 |
- 2) 互換性がある部品の変更の場合

| | | | | | | |
|-----|---|---------------|-------------|----------|--------------------|---|
| 1 | ☆ | B1234-200-000 | Frame cover | D, 12/74 | B1234-300-000 ↑ | — |
| 1-1 | ☆ | B1234-300-000 | Frame cover | A, 12/74 | フレームカバー | 1 |

この場合は新しい品番でご注文下さい。

CONTENTS

目 次

| | |
|---|----|
| 1. MACHINE HEAD & MISCELLANEOUS COVER COMPONENTS 頭部外装関係 | 1 |
| 2. UPPER MAIN SHAFT, THREAD TAKE-UP & SAFETY CLUTCH MECHANISM COMPONENTS 上軸、天秤、安全装置関係 | 3 |
| 3. NEEDLE BAR, FEED ROCK SHAFT COMPONENTS 針棒、水平送り軸関係 | 5 |
| 4. PRESSER BAR & WALKING FOOT COMPONENTS 押エ棒、上送り関係 | 7 |
| 5. SEWING HOOK SHAFT COMPONENTS 下軸、水平釜関係 | 9 |
| 6. KNEE LIFTER AND OIL RESERVOIR COMPONENTS 膝上げ、油溜関係 | 11 |
| 7. EXCHANGING GAUGE PARTS 交換ゲージ部品 | 13 |
| 8. NUMERICAL INDEX OF PARTS 索引 | 16 |

1. MACHINE HEAD & MISCELLANEOUS COVER COMPONENTS

頭部外裝關係

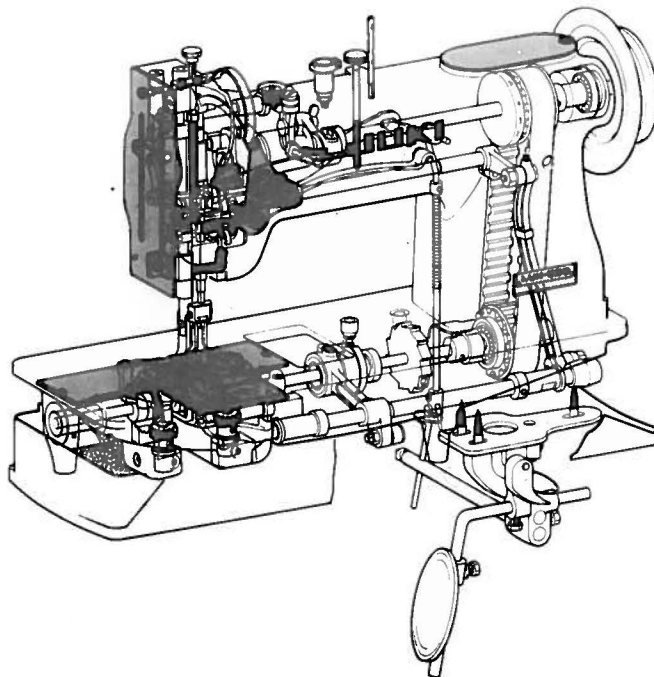
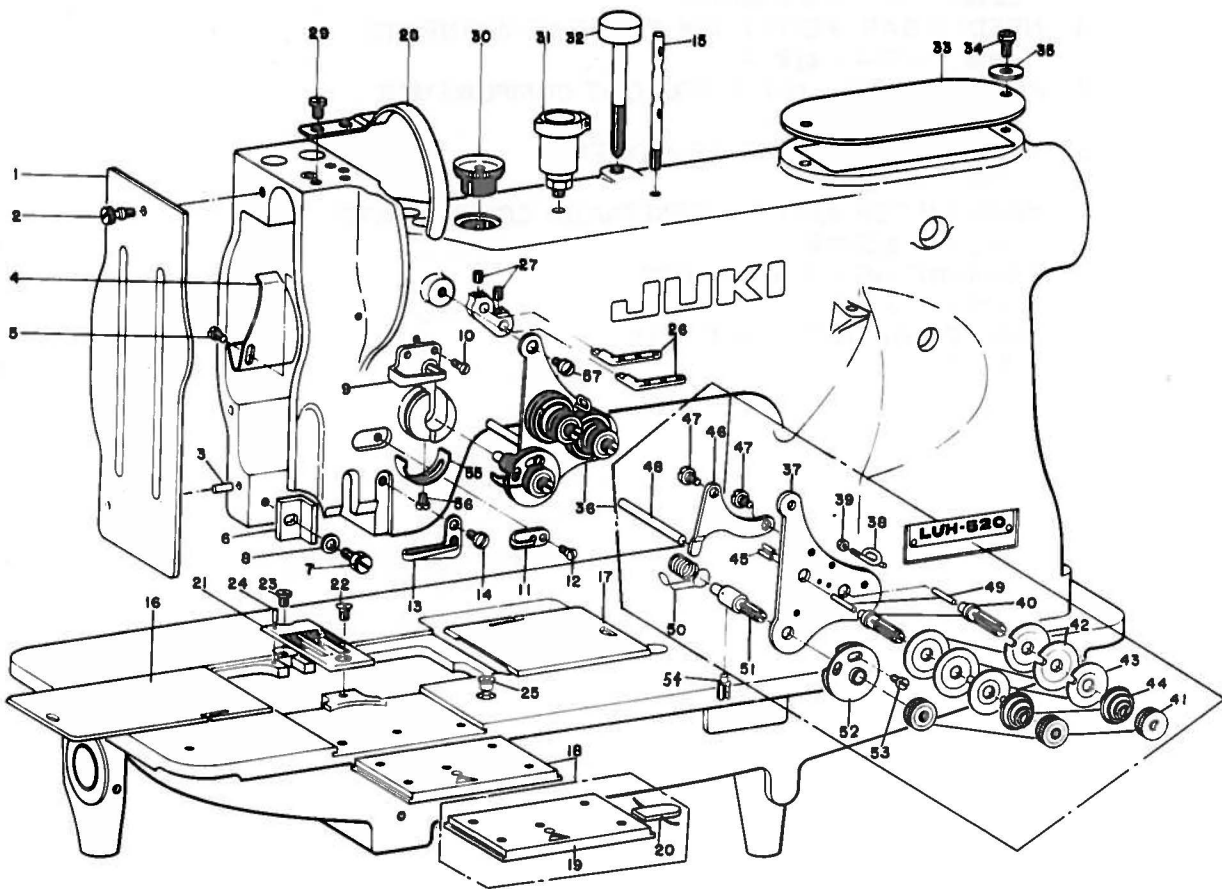

1. MACHINE HEAD & MISCELLANEOUS COVER COMPONENTS

頭部外装関係

| Ref. No. | Note | Part No. | Description | E.C. | Amt. Req. | |
|----------|------|---------------|--|------|-----------------------|-----|
| | 注記 | 品番 | | 変更年月 | 品名 | 数量 |
| 1 | | B3101-053-000 | Face plate | | 面板 | 1 |
| 2 | | B3106-019-000 | . . . Set screw | | 面板止ネジ | 1 |
| 3 | | B1103-051-000 | . . . Set pin | | 面板止ピン | 1 |
| 4 | | B1140-051-000 | Thread take-up oil shield | | 天秤油防板 | 1 |
| 5 | | SS-3090610-SP | . . . Set screw | | 天秤油防板止ネジ | 1 |
| 6 | | B1423-051-000 | Needle bar frame guide | | 針棒揺動台案内 | 1 |
| 7 | | SS-9111010-SP | . . . Set screw | | 針棒揺動台案内止ネジ | 1 |
| 8 | | WP-0480856-SP | . . . Washer | | 針棒揺動台案内止ネジ座金 | 1 |
| 9 | | B1129-563-000 | Frame thread guide, upper | | 糸案内 (上) | 1 |
| 10 | | SS-2090710-SP | . . . Set screw | | 糸案内 (上) 止ネジ | 2 |
| 11 | | B1130-051-000 | Frame thread guide, middle | | 糸案内 (中) | 1 |
| 12 | | SS-2090710-SP | . . . Set screw | | 糸案内 (中) 止ネジ | 1 |
| 13 | | B1131-051-000 | Frame thread guide, lower | | 糸案内 (下) | 1 |
| 14 | | SS-2090710-SP | . . . Set screw | | 糸案内 (下) 止ネジ | 1 |
| 15 | | B1114-051-000 | Needle thread guide pin | | 糸案内棒 | 1 |
| 16 | | B1112-512-E00 | Bed slide, left (3/8") standard | | 滑り板 (左)(3/8")標準 | 1 |
| 17 | | B1113-512-E00 | Bed slide, right (3/8") standard | | 滑り板 (右)(3/8")標準 | 1 |
| 18 | | B1110-051-0A0 | Bed slide asm. | | 滑り板 (組) | 1 |
| 19 | | B1110-051-000 | Bed slide | | 滑り板 | (1) |
| 20 | | B1111-051-0A0 | . . . Stopper | | 滑り板止メ | (1) |
| 21 | | B1109-520-K00 | Throat plate (3/8") standard | | 針板 (3/8")標準 | 1 |
| 22 | | SS-2110920-TP | . . . Set screw | | 針板止ネジ | 1 |
| 23 | | SS-6090630-SP | . . . Guide screw | | 針板案内ネジ | 1 |
| 24 | | B1104-051-000 | . . . Stopper pin | | 針板止ピン | 1 |
| 25 | | B1157-009-0A0 | Oil cup, small | | オイルカップ (小) | 3 |
| 26 | | B1128-051-000 | Three-hole thread eyelet | | 三目糸掛ケ | 2 |
| 27 | | SS-8110510-SP | . . . Set screw | | 三目糸掛ケ止ネジ | 2 |
| 28 | | B1158-563-000 | Thread take-up cover | | 天秤カバー | 1 |
| 29 | | SS-7160740-SP | . . . Set screw | | 天秤カバー止ネジ | 2 |
| 30 | | B3501-051-000 | Upper main shaft front bushing oiling tube | | 上軸前メタル油注入筒 | 1 |
| 31 | | B1155-053-000 | Upper feed rod oil cup | | 上送りロッドオイルカップ | 1 |
| 32 | | B1509-051-000 | Pressure regulating thumb screw | | 押工調節ネジ | 1 |
| 33 | | B1150-051-000 | Top cover | | 天板 | 1 |
| 34 | | SD-0630241-SD | . . . Set screw | | 天板止ネジ | 1 |
| 35 | | B1152-051-000 | . . . Washer | | 天板止ネジ座金 | 1 |
| 36 | | B3121-520-0B0 | Thread controller base asm. | | 糸調子台板 (組) | 1 |
| 37 | | B3121-520-000 | Thread controller base | | 糸調子台板 | (1) |
| 38 | | B3114-761-000 | Thread tension disc thread guide | | 糸調子皿糸案内 | (1) |
| 39 | | NS-6060350-SP | . . . Nut | | 糸調子皿糸案内締ナット | (1) |
| 40 | | B3124-051-000 | Thread tension post | | 糸調子棒 | (2) |
| 41 | | B3125-012-000 | Thread tension nut | | 糸調子ナット | (3) |
| 42 | | B3126-051-000 | Thread tension disc | | 糸調子皿 | (4) |
| 43 | | B3132-051-000 | . . . Presser | | 糸調子皿押エ | (2) |
| 44 | | B3129-053-000 | Thread tension spring | | 糸調子バネ | (2) |
| 45 | | B3131-051-000 | Thread tension spring stopper pin | | 糸調子皿止ピン | (2) |
| 46 | | B3134-520-000 | Thread release lever | | 糸ユルメ板 | (1) |
| 47 | | SD-0470281-SP | . . . Set screw | | 糸ユルメ板止ネジ | (2) |
| 48 | | B3122-051-000 | Thread release lever pushing bar | | 糸ユルメ押し棒 | (1) |
| 49 | | B3127-051-000 | Thread release pin | | 糸ユルメピン | (2) |
| 50 | | B3128-520-000 | Take-up spring | | 糸取りバネ | (1) |
| 51 | | B3123-520-000 | . . . Stud | | 糸取りバネ軸 | (1) |
| 52 | | B3137-520-0A0 | . . . Guide asm. | | 糸取りバネ案内 (組) | (1) |
| 53 | | SS-6080810-SP | . . . Guide disc set screw | | 糸取りバネ案内皿止ネジ | (1) |
| 54 | | SS-8111251-SP | . . . Stud screw | | 糸取りバネ軸止ネジ | 1 |
| 55 | | B3138-051-000 | Take-up spring adjusting plate | | 糸取りバネ調節板 | 1 |
| 56 | | SS-7090520-SP | . . . Set screw | | 糸取りバネ調節板止ネジ | 1 |
| 57 | | SS-7110720-SP | Thread controller base set screw | | 糸調子台板止ネジ | 1 |

2. UPPER MAIN SHAFT, THREAD TAKE-UP & SAFETY CLUTCH MECHANISM COMPONENTS

上軸、天秤、安全裝置關係

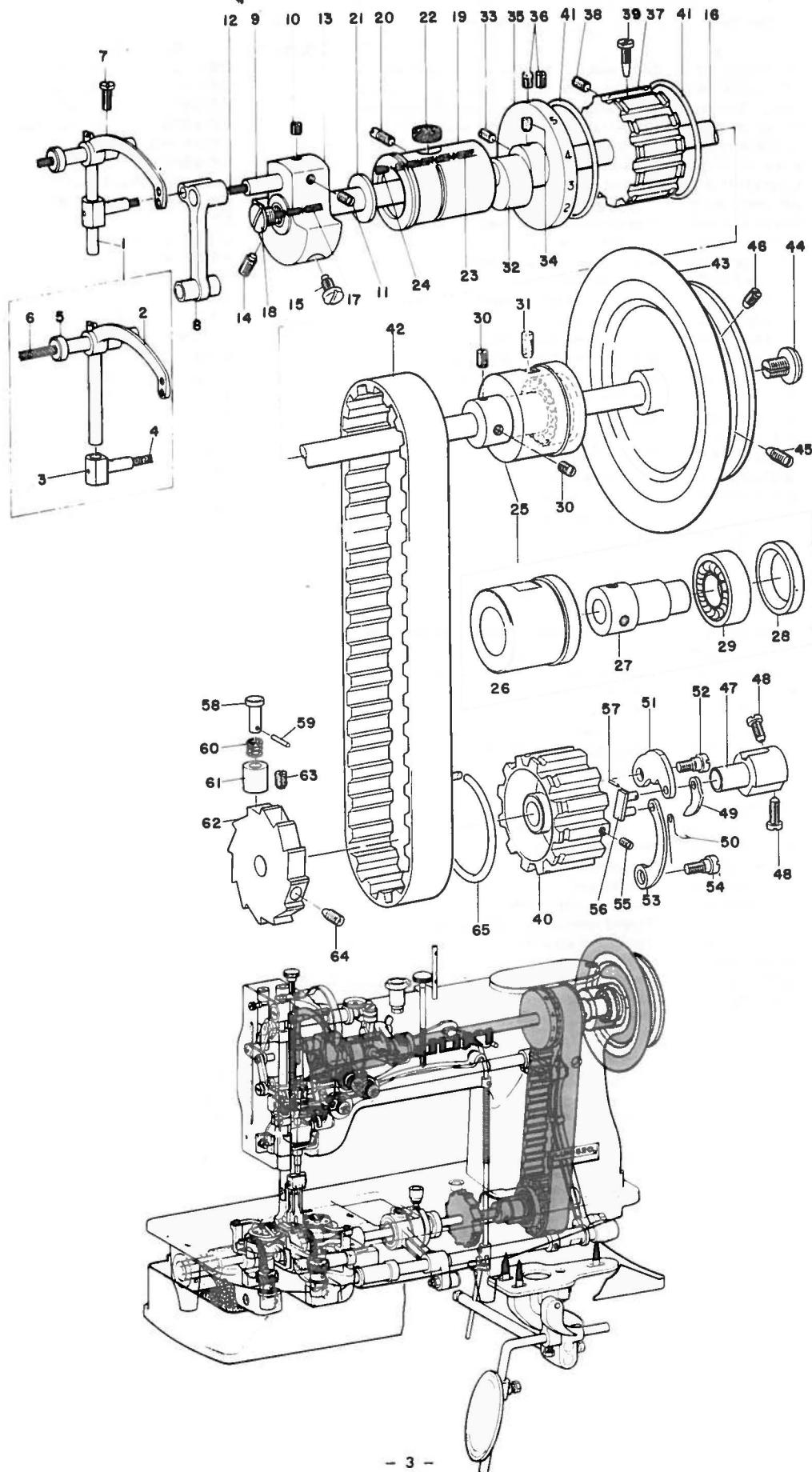

2. UPPER MAIN SHAFT, THREAD TAKE-UP & SAFETY CLUTCH MECHANISM COMPONENTS

上軸、天秤、安全装置関係

| Ref. No. | Note | Part No. | Description | E.C. | 品名 | Amt. Req. |
|----------|------|---------------|---|------|-------------------------|-----------|
| | 注記 | 品番 | | 変更年月 | | 数量 |
| 1 | | B1905-520-0C0 | Take-up lever asm..... | | 天秤(組)..... | 1 |
| 2 | | B1905-520-000 | Take-up lever | | 天秤 | (1) |
| 3 | | B1907-057-000 | Take-up lever pin | | 天秤スライド軸..... | (1) |
| 4 | | CQ-2020000-00 | Oil wick | | 天秤スライド軸油心..... | (1) |
| 5 | | B1906-051-000 | Take-up slide shaft | | 天秤支工軸..... | (1) |
| 6 | | CQ-2520000-00 | Oil wick | | 天秤支工軸油心..... | (1) |
| 7 | | SS-7151120-SP | Set screw | | 天秤支工軸止ネジ..... | 1 |
| 8 | | B1408-051-000 | Needle bar crank rod | | 針棒クランクロッド..... | 1 |
| 9 | | B1210-051-000 | Needle bar crank pin | | 針棒クランクピン..... | 1 |
| 10 | | SS-8680540-SP | Set screw (1) | | 針棒クランクピン止ネジ(1)..... | 1 |
| 11 | | SS-8680730-SP | Set screw (2) | | 針棒クランクピン止ネジ(2)..... | 1 |
| 12 | | CQ-3030000-00 | Oil wick | | 針棒クランクピン油心..... | 1 |
| 13 | | B1206-520-000 | Counterweight | | 釣合錘..... | 1 |
| 14 | | SS-8681650-TP | Set screw | | 釣合錘止ネジ..... | 1 |
| 15 | | SS-7681750-TP | Set screw (S) | | 釣合錘止ネジ(S)..... | 1 |
| 16 | | D1201-055-B00 | Upper main shaft | | 上軸..... | 1 |
| 17 | | CQ-5050000-00 | Oil wick | | 上軸油心..... | 1 |
| 18 | | B1207-051-000 | Oil stopping screw | | 上軸油止ネジ..... | 1 |
| 19 | | B1202-051-000 | Front bushing | | 上軸前メタル..... | 1 |
| 20 | | SS-8151350-SP | Set screw | | 上軸前メタル止ネジ..... | 1 |
| 21 | | B1205-051-000 | Washer | | 上軸前メタル座金..... | 1 |
| 22 | | B1203-051-000 | Felt | | 上軸前メタルフェルト..... | 1 |
| 23 | | CQ-2520000-00 | Oil wick | | 上軸前メタル油心..... | 1 |
| 24 | | B1230-051-000 | Stopping plug | | 上軸前メタル油心止栓..... | 1 |
| 25 | | B1216-051-0A0 | Upper main shaft rear bushing asm..... | | 上軸後メタル(組)..... | 1 |
| 26 | | B1216-051-000 | Rear bushing (1) | | 上軸後メタル(1)..... | (1) |
| 27 | | B1217-051-000 | Rear bushing (2) | | 上軸後メタル(2)..... | (1) |
| 28 | | B1218-051-000 | Upper main rear bearing retaining collar | | 上軸後ベアリング止..... | (1) |
| 29 | | B1219-051-000 | Bearing | | 上軸後ベアリング..... | (1) |
| 30 | | SS-8150710-SP | Upper main shaft rear bushing set screw (2) | | 上軸後メタル(2)止ネジ..... | (2) |
| 31 | | SS-8151350-SP | Set screw | | 上軸後メタル止ネジ..... | 1 |
| 32 | | D1450-055-B00 | Feed eccentric | | 上送りカム..... | 1 |
| 33 | | SS-8660530-TP | Set screw (A) | | 上送りカム止ネジ(A)..... | 1 |
| 34 | | SS-8660970-TP | Set screw (B) | | 上送りカム止ネジ(B)..... | 1 |
| 35 | | B1220-562-000 | Stitch graduator | | 送り目盛板..... | 1 |
| 36 | | SS-8151230-SP | Set screw | | 送り目盛板止ネジ..... | 2 |
| 37 | | B1302-051-000 | Sprocket wheel, upper | | 上スプロケット..... | 1 |
| 38 | | SS-8681650-TP | Set screw (A)..... | | 上スプロケット止ネジ(A)..... | 1 |
| 39 | | SS-7681750-TP | Set screw (B) | | 上スプロケット止ネジ(B)..... | 1 |
| 40 | | B1303-055-A00 | Sprocket wheel, lower | | 下スプロケット..... | 1 |
| 41 | | B1214-019-000 | Sprocket ring, upper | | 上スプロケットリング..... | 2 |
| 42 | | B1301-051-000 | Timing belt | | タイミングベルト..... | 1 |
| 43 | | B1227-520-000 | Hand wheel | | ハズミ車..... | 1 |
| 44 | | B1233-012-000 | End screw | | ハズミ車押シ上ゲネジ..... | 1 |
| 45 | | SS-8151780-SP | Set screw (S) | | ハズミ車止ネジ(S)..... | 1 |
| 46 | | SS-8152030-SP | Set screw | | ハズミ車止ネジ..... | 1 |
| 47 | | B1311-055-000 | Safety clutch body | | 安全装置受ケ..... | 1 |
| 48 | | B1316-055-000 | Clamp screw | | 安全装置受締ネジ..... | 2 |
| 49 | | B1308-055-000 | Safety clutch counter-hook | | 安全装置逆爪..... | 1 |
| 50 | | B1309-055-000 | Spring | | 安全装置逆爪バネ..... | 1 |
| 51 | | B1307-055-000 | Safety clutch hook | | 安全装置爪..... | 1 |
| 52 | | SD-0640322-TP | Hinge screw | | 安全装置爪段ネジ..... | 1 |
| 53 | | B1305-055-000 | Safety clutch spring | | 安全装置バネ..... | 1 |
| 54 | | SD-0640322-TP | Hinge screw | | 安全装置バネ段ネジ..... | 1 |
| 55 | | SS-8090710-SP | Positioning screw | | 安全装置バネ押シネジ..... | 1 |
| 56 | | B1310-055-000 | Small link | | 安全装置小リンク..... | 1 |
| 57 | | B1314-055-000 | Pin | | 安全装置小リンクピン..... | 1 |
| 58 | | B1312-055-000 | Safety clutch push button | | 安全装置押シボタン..... | 1 |
| 59 | | PS-0200102-KH | Pin | | 安全装置押シボタンピン..... | 1 |
| 60 | | B1639-051-000 | Spring | | 安全装置押シボタンバネ..... | 1 |
| 61 | | B1313-055-000 | Button tube | | 安全装置ボタン筒..... | 1 |
| 62 | | B1314-057-000 | Safety clutch ratchet gear | | 安全装置ラチェットギヤー..... | 1 |
| 63 | | SS-8151780-SP | Set screw (A)..... | | 安全装置ラチェットギヤー止ネジ(A)..... | 1 |
| 64 | | SS-8152080-SP | Set screw (B) | | 安全装置ラチェットギヤー止ネジ(B)..... | 1 |
| 65 | | B1214-019-000 | Sprocket ring, lower | | 下スプロケットリング..... | 1 |

3. NEEDLE BAR, FEED ROCK SHAFT COMPONENTS

針棒、水平送り軸関係

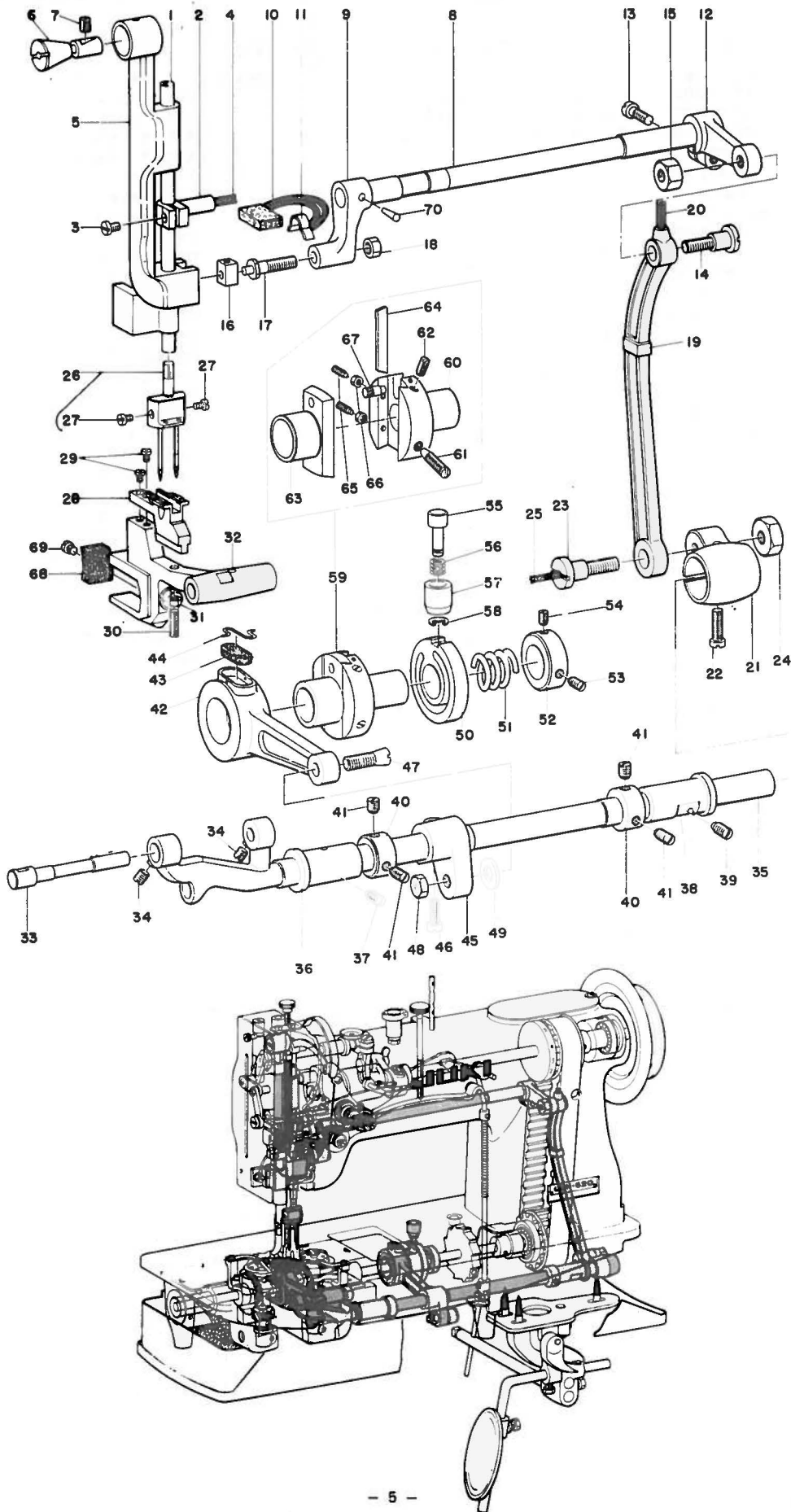

3. NEEDLE BAR, FEED ROCK SHAFT COMPONENTS

針棒、水平送り軸関係

| Ref. No. | Note | Part No. | Description | E.C. 変更年月 | Amt. Req. 数量 |
|----------|------|---------------|---|--------------|-----------------|
| 1 | 注記 | B1401-518-000 | Needle bar | | 1 |
| 2 | | B1411-518-0A0 | Connection | | 1 |
| 3 | | SS-7090910-SP | Set screw | | (1) |
| 4 | | CQ-3030000-00 | Oil wick | | 1 |
| 5 | | B1420-518-000 | Frame rock base | | 1 |
| 6 | | B1421-051-000 | Taper stud | | 1 |
| 7 | | SS-B151160-SP | Set screw | | 1 |
| 8 | | B1429-051-000 | Needle bar frame rock shaft | | 1 |
| 9 | | B1428-051-000 | Needle bar shaft front crank | | 1 |
| 10 | | B1438-051-0A0 | Oil wick asm. | | 1 |
| 11 | | B1437-051-000 | Oil wick retainer | | 1 |
| 12 | | B1431-520-0A0 | Needle bar shaft rear crank | | 1 |
| 13 | | SS-6151440-SP | Set screw | | (1) |
| 14 | | SD-0790801-SP | Hinge screw | | 1 |
| 15 | | NS-6160520-SP | Nut | | 1 |
| 16 | | B1425-051-000 | Needle bar frame slide block | | 1 |
| 17 | | B1426-051-000 | Shaft | | 1 |
| 18 | | NS-6620310-SP | Nut | | 1 |
| 19 | | B1434-051-000 | Needle bar frame driving rod | | 1 |
| 20 | | CQ-2520000-00 | Oil wick | | 1 |
| 21 | | B1435-051-0A0 | Driving crank | | 1 |
| 22 | | SS-6151920-SP | Clamp screw | | (1) |
| 23 | | SD-0950801-SP | Hinge screw | | 1 |
| 24 | | NS-6700420-SP | Nut | | 1 |
| 25 | | CQ-2020000-00 | Oil wick | | 1 |
| 26 | | B1402-520-KA0 | Needle clamp (3/8") standard ASM. | | 1 |
| 27 | | SS-6090410-TP | Needle set screw | | (2) |
| 28 | | B1613-520-K00 | Feed dog (3/8") standard | | 1 |
| 29 | | SS-6080720-SP | Set screw | | 2 |
| 30 | | SS-8081450-SP | Adjusting screw | | 1 |
| 31 | | NS-6080210-SP | Nut | | 1 |
| 32 | | B1602-520-0A0 | Feed bar asm. | | 1 |
| 33 | | B1603-051-000 | Feed bar shaft | | 1 |
| 34 | | SS-8110510-SP | Set screw | | 2 |
| 35 | | B1601-051-000 | Feed rock shaft | | 1 |
| 36 | | B1607-051-000 | Front bushing | | 1 |
| 37 | | SS-8151150-SP | Set screw | | 1 |
| 38 | | B1609-051-000 | Feed rock shaft rear bushing | | 1 |
| 39 | | SS-8152030-SP | Set screw | | 1 |
| 40 | | CS-1401012-SC | Feed rock shaft thrust collar | | 2 |
| 41 | | SS-8150410-SP | Set screw | | 4 |
| 42 | | B1614-057-000 | Feed rock shaft rod | | 1 |
| 43 | | B1702-012-000 | Felt | | 1 |
| 44 | | B1213-012-000 | Presser | | 1 |
| 45 | | B1616-520-0A0 | Feed rock shaft crank | | 1 |
| 46 | | SS-6111210-SP | Set screw | | (1) |
| 47 | | B1621-012-A00 | Taper screw | | 1 |
| 48 | | NS-6680480-SP | Taper screw nut | | 1 |
| 49 | | B1615-520-000 | Feed rock shaft rod washer | | 1 |
| 50 | | B1626-562-000 | Feed eccentric guide | | 1 |
| 51 | | B1624-055-000 | Feed eccentric body spring | | 1 |
| 52 | | B1625-057-000 | Retainer collar for eccentric body spring | | 1 |
| 53 | | SS-8110510-SP | Set screw (A) | | 1 |
| 54 | | SS-8110750-SP | Set screw (B) | | 1 |
| 55 | | B1636-055-000 | Feed adjusting knob | | 1 |
| 56 | | B1639-051-000 | Spring | | 1 |
| 57 | | B1637-055-000 | Feed eccentric guide bushing | | 1 |
| 58 | | RE-0500000-K0 | Snap ring | | 1 |
| 59 | | B1620-562-0B0 | Feed adjusting body asm. | | 1 |
| 60 | | B1621-055-000 | Feed adjusting body | | (1) |
| 61 | | SS-8151770-SP | Set screw (A) | | (1) |
| 62 | | SS-8151780-SP | Set screw (B) | | (1) |
| 63 | | B1620-057-000 | Feed adjuster | | (1) |
| 64 | | B1622-057-000 | Friction plate | | (1) |
| 65 | | B1642-057-000 | Set screw | | (2) |
| 66 | | NS-6080210-SP | Nut | | (2) |
| 67 | | B1623-057-000 | Lead cam pin | | (1) |
| 68 | | B1605-051-000 | Feed bar fork oil supply felt | | 1 |
| 69 | | SS-6080610-TP | Set screw | | 1 |
| 70 | | PT-0301600-S0 | Knock pin, for front crank | | 1 |
| 71 | | MDI-300B240I | Needle | | 2 |

4. PRESSER BAR & WALKING FOOT COMPONENTS

押工棒、上送り関係

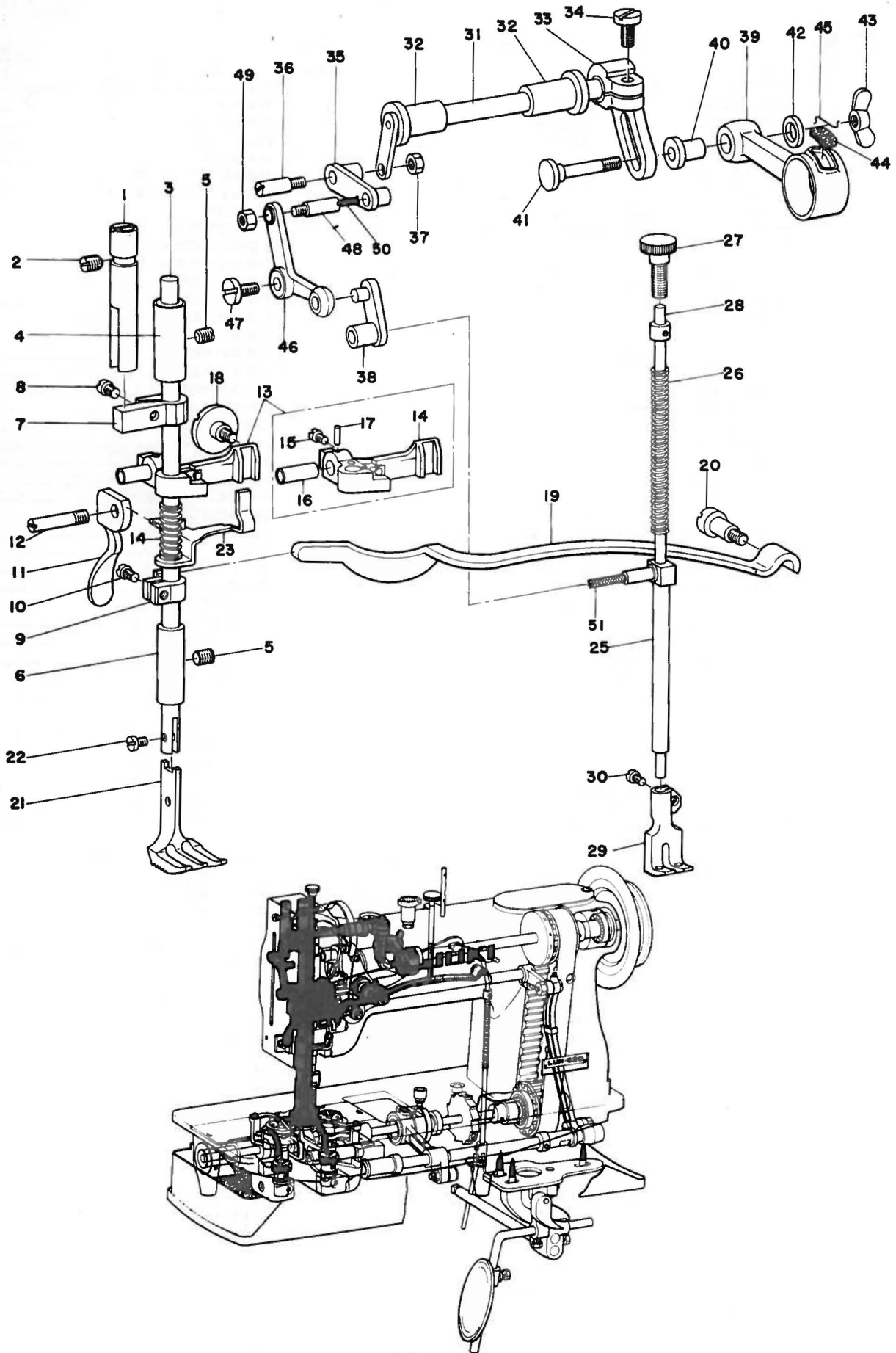

4. PRESSER BAR & WALKING FOOT COMPONENTS

押エ棒、上送り関係

| Ref. No. | Note | Part No. | Description | E.C. | Amt. Req. |
|----------|------|---------------|--|-----------------------|-----------|
| | 注記 | 品番 | | 変更年月 | 数量 |
| 1 | | B1502-051-000 | Presser bar guide sleeve | 押エ棒案内筒 | 1 |
| 2 | | SS-8151150-SP | . . . Set screw | 押エ棒案内筒止ネジ | 1 |
| 3 | | B1501-040-000 | Presser bar | 押エ棒 | 1 |
| 4 | | B1503-051-A00 | . . . Upper bushing | 押エ棒上メタル | 1 |
| 5 | | SS-8151150-SP | . . . Set screw | 押エ棒メタル止ネジ | 2 |
| 6 | | B1503-051-B00 | . . . Lower bushing | 押エ棒下メタル | 1 |
| 7 | | B1504-051-0A0 | Presser bar connection | 押エ棒抱キ案内 | 1 |
| 8 | | SS-7090910-SP | . . . Set screw | 押エ棒抱キ案内止ネジ | (1) |
| 9 | | B1507-051-0A0 | Presser bar connection <i>2 sm</i> | 押エ棒抱キ (組) | 1 |
| 10 | | SS-7090910-SP | . . . Set screw | 押エ棒抱キ止ネジ | (1) |
| 11 | | B1512-051-000 | Hand lifter | 押エ上ゲ | 1 |
| 12 | | B1515-051-000 | . . . Shaft | 押エ上ゲ軸 | 1 |
| 13 | | B1460-053-0A0 | Hand lifter mounting bracket asm. | 押エ上ゲテコ台(組) | 1 |
| 14 | | B1460-053-00A | Hand lifter mounting bracket | 押エ上ゲテコ台 | (1) |
| 15 | | SS-7111310-SP | . . . Clamp screw | 押エ上ゲテコ台締ネジ | (1) |
| 16 | | B1460-053-00B | . . . Connecting pin | 押エ上ゲテコ台結合軸 | (1) |
| 17 | | PT-0201200-S0 | Pin | 押エ上ゲテコ台結合軸ノックピン | (1) |
| 18 | | SD-0800481-SP | Hinge screw, for bracket | 押エ上ゲテコ案内段ネジ | 1 |
| 19 | | B1505-053-000 | Presser bar adjusting plate spring | 押エ調節板バネ | 1 |
| 20 | | SD-0801601-SP | . . . Screw stud | 押エ調節板バネ支エネジ | 1 |
| 21 | | B1525-520-K00 | Presser foot (3/8") standard | 押エ外足(3/8")標準 | 1 |
| 22 | | SS-6090910-TP | . . . Set screw | 押エ止ネジ | 1 |
| 23 | | B1461-053-0A0 | Thread release guide | 糸コルメ受板(組) | 1 |
| 24 | | B1462-053-000 | . . . Spring | 糸コルメ受板バネ | 1 |
| 25 | | B1466-053-000 | Walking bar | 上送り棒 | 1 |
| 26 | | B1468-053-000 | . . . Spring | 上送り棒押エバネ | 1 |
| 27 | | B1469-053-000 | Adjusting thumb screw, for walking bar | 上送り押エ棒調節ネジ | 1 |
| 28 | | B1467-053-0A0 | Spring pole, for walking bar asm. | 上送りバネ支持棒(組) | 1 |
| 29 | | B1470-520-KA0 | Walking foot (3/8") standard | 押エ中足(3/8")標準 | 1 |
| 30 | | SS-6110710-TP | Walking foot clamp screw | 上送り足締ネジ | (1) |
| 31 | | B1456-053-000 | Walking bar shaft | 上送り軸 | 1 |
| 32 | | B1455-053-000 | Bushing | 上送り軸メタル | 2 |
| 33 | | D1454-055-BA0 | Upper feed spring rod | 上送り腕 | 1 |
| 34 | | SS-7161640-SP | . . . Clamp screw | 上送り腕締ネジ | (1) |
| 35 | | B1458-053-000 | Walking bar rock shaft connecting link | 上送り連結リンク | 1 |
| 36 | | B1457-055-000 | Hinge screw | 上送り連結段ネジ | 1 |
| 37 | | NS-6660430-SP | Hinge screw nut | 上送り連結段ネジナット | 1 |
| 38 | | B1465-053-000 | Walking bar driving link | 上送り揺動リンク | 1 |
| 39 | | D1453-055-B00 | Upper feed rod | 上送りロッド | 1 |
| 40 | | D1455-055-B00 | Wing screw bolt bushing | 上送りロッド連結軸 | 1 |
| 41 | | D1456-055-B00 | Wing screw bolt | 上送りロッド連結軸段ネジ | 1 |
| 42 | | D1457-055-B00 | Wing screw washer | 上送りロッド連結軸段ネジ座金 | 1 |
| 43 | | D1458-055-B00 | Wing screw | 上送りロッド連結軸蝶ナット | 1 |
| 44 | | B1702-012-000 | Oil felt | 上送りロッドフェルト | 1 |
| 45 | | B1213-012-000 | . . . Retainer | 上送りロッドフェルト押エ | 1 |
| 46 | | B1459-053-00A | L-shaped link | L型リンク | 1 |
| 47 | | SS-6111140-SP | . . . Set screw | L型リンク止ネジ | 1 |
| 48 | | B1459-053-00B | . . . Link stud | L型リンク結合軸 | 1 |
| 49 | | NS-6110310-SP | . . . Lock nut | L型リンク結合軸固定ナット | 1 |
| 50 | | CQ-2020000-00 | . . . Oil wick | L型リンク結合軸油心 | 1 |
| 51 | | CQ-2020000-00 | Walking bar oil wick | 上送り棒油心 | 1 |

5. SEWING HOOK SHAFT COMPONENTS

下軸、水平釜関係

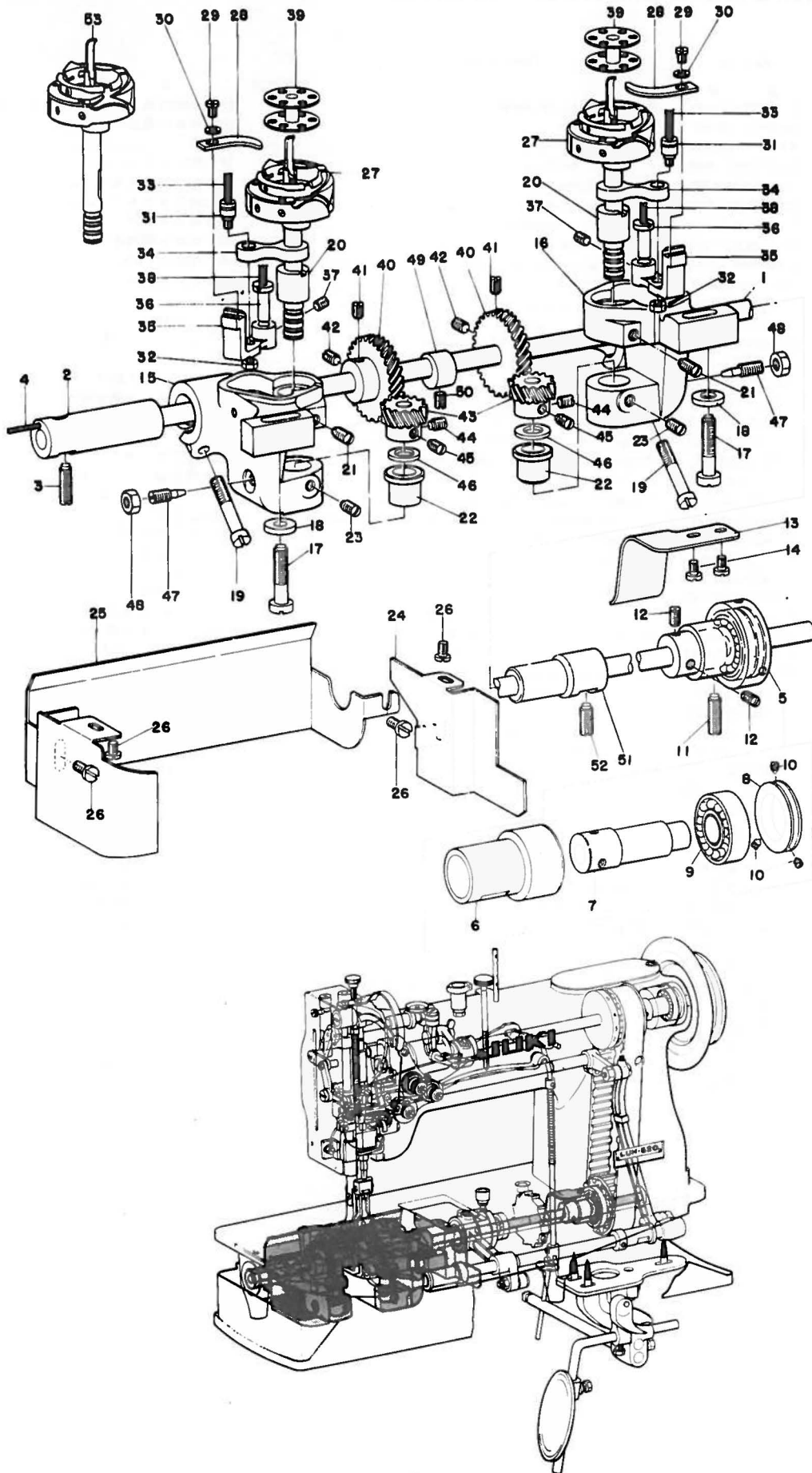

5. SEWING HOOK SHAFT COMPONENTS

下軸、水平釜関係

| Ref. No. | Note | Part No. | Description | E.C. | 品名 | Amt. Req. |
|----------|------|---------------|---|------|----------------------------|-----------|
| | 注記 | 品番 | | 変更年月 | | 数量 |
| 1 | | B1801-520-000 | Hook shaft | | 下軸 | 1 |
| 2 | | B1802-051-000 | ... Front bushing | | 下軸前メタル | 1 |
| 3 | | SS-8152030-SP | ... Set screw | | 下軸前メタル止ネジ | 1 |
| 4 | | CQ-2020000-00 | ... Oil wick | | 下軸前メタル油心 | 1 |
| 5 | | B1807-051-0A0 | Rear bushing asm., for hook shaft asm. | | 下軸後メタル(組) | 1 |
| 6 | | B1807-051-000 |(1) | | 下軸後メタル(1) | (1) |
| 7 | | B1808-051-000 |(2) | | 下軸後メタル(2) | (1) |
| 8 | | B1809-051-000 | Bearing retaining collar | | 下軸ベアリング止 | (1) |
| 9 | | B1219-051-000 | Hook shaft bearing | | 下軸ベアリング | (1) |
| 10 | | SS-8090530-TP | Bearing retaining collar screw | | 下軸ベアリング受止ネジ | (3) |
| 11 | | SS-8152030-SP | Screw for hook shaft rear bushing | | 下軸後メタル止ネジ | 1 |
| 12 | | SS-8150750-SP | Screw (2) for hook shaft rear bushing | | 下軸後メタル(2)止ネジ | 2 |
| 13 | | B1806-520-000 | Hook shaft timing indicator | | 下軸指示板 | 1 |
| 14 | | SS-7090520-SP | ... Set screw | | 下軸指示板止ネジ | 2 |
| 15 | | B1810-520-000 | Hook driving shaft saddle (left) | | 釜軸台(左) | 1 |
| 16 | | B1811-563-000 | ... (Right) | | 釜軸台(右) | 1 |
| 17 | | SS-7762840-SP | ... Set screw | | 釜軸台止ネジ | 2 |
| 18 | | B1821-051-000 | ... Washer | | 釜軸台止ネジ座金 | 1 |
| 19 | | SS-6153040-SP | ... Pinch screw | | 釜軸台締ネジ | 2 |
| 20 | | B1814-563-000 | Hook driving shaft upper bushing | | 釜軸上メタル | 2 |
| 21 | | SS-8151150-SP | ... Set screw | | 釜軸上メタル止ネジ | 2 |
| 22 | | B1815-563-000 | Lower bushing, for hook driving | | 釜軸下メタル | 2 |
| 23 | | SS-8150710-SP | ... Set screw | | 釜軸下メタル止ネジ | 2 |
| 24 | | B1838-520-000 | Oil shield(A), for saddle | | 釜軸台油防板(A) | 1 |
| 25 | | B1844-520-000 | ... (B) | | 釜軸台油防板(B) | 1 |
| 26 | | SS-6110610-TP | ... Set screw | | 釜軸台油防板止ネジ | 4 |
| 27 | | B1830-563-BA0 | Vertical-axis sewing hook (B) asm. | | 水平釜(B)組 | 2 |
| 28 | | B1824-563-000 | Bobbin case opening lever | | 中釜案内 | 2 |
| 29 | | SS-6090620-SP | ... Set screw | | 中釜案内止ネジ | 2 |
| 30 | | WP-0371016-SD | ... Washer | | 中釜案内止ネジ座金 | 2 |
| 31 | | B1821-051-000 | ... Crank screw stud | | 中釜案内クランクピン | 2 |
| 32 | | NS-6110420-SP | ... Nut | | 中釜案内クランクピンナット | 2 |
| 33 | | CQ-2020000-00 | ... Oil wick | | 中釜案内クランクピン油心 | 2 |
| 34 | | B1820-051-000 | ... Link | | 中釜案内リンク | 2 |
| 35 | | B1822-563-000 | ... Crank | | 中釜案内腕 | 2 |
| 36 | | B1823-051-000 | ... Crank pin | | 中釜案内腕軸 | 2 |
| 37 | | SS-8151230-SP | ... Set screw | | 中釜案内腕軸止ネジ | 2 |
| 38 | | CQ-2020000-00 | ... Oil wick | | 中釜案内腕軸油心 | 2 |
| 39 | | B9117-563-000 | Bobbin | | ボビン | 2 |
| 40 | | B1816-051-000 | Hook shaft gear (large) | | ネジ歯車(大) | 2 |
| 41 | | SS-8660970-TP | ... Set screw | | ネジ歯車大止ネジ | 2 |
| 42 | | SS-8660810-TP | ... Set screw | | ネジ歯車(大)止ネジ | 2 |
| 43 | | B1817-051-000 | Hook shaft gear (small) | | ネジ歯車(小) | 2 |
| 44 | | SS-8660530-TP | ... Set screw | | ネジ歯車(小)止ネジ | 2 |
| 45 | | SS-8660670-SP | ... Set screw | | ネジ歯車小止ネジ | 2 |
| 46 | | B1818-051-000 | ... Thrust plate | | ネジ歯車小スラスト板 | 2 |
| 47 | | B1843-563-000 | Oil adjusting screw | | 釜油量調節ネジ | 2 |
| 48 | | NS-6110420-SP | ... Nut | | 釜油量調節ネジナット | 2 |
| 49 | | B1840-051-000 | Feed driving eccentric | | 上下送りカム | 1 |
| 50 | | SS-8150580-SP | ... Set screw | | 上下送りカム止ネジ | 1 |
| 51 | | B1804-051-000 | Hook shaft intermediate bushing | | 下軸中メタル | 1 |
| 52 | | SS-8151550-SP | ... Set screw | | 下軸中メタル止ネジ | 1 |
| 53 | 001 | B1830-563-0A0 | Vertical-axis sewing hook (A) asm. (for round hole feed) | | 水平釜(A)(組) (送り丸穴用) | 2 |

001 は特注部品です

001 Special order part

6. KNEE LIFTER AND OIL RESERVOIR COMPONENTS

膝上げ、油溜関係

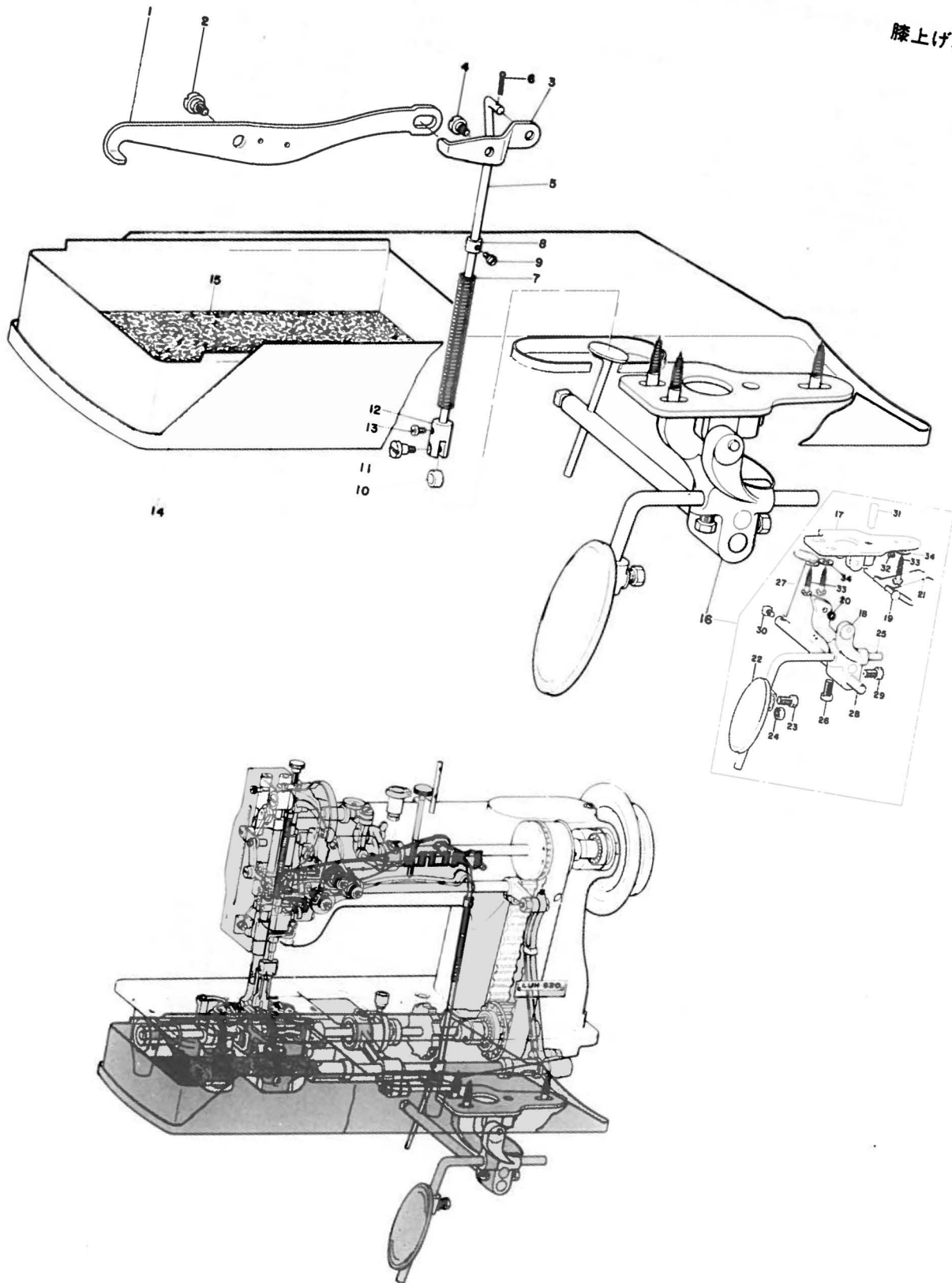

6. KNEE LIFTER AND OIL RESERVOIR COMPONENTS

膝上げ、油溜関係

| Ref. No. | Note | Part No. | Description | E.C. | | Amt. Req. |
|----------|------|---------------|--|------|-------------------|-----------|
| | 注記 | 品番 | | 変更年月 | 品名 | 数量 |
| 1 | | B3409-053-000 | Knee lifter front lever | | 膝上げ前テコ | 1 |
| 2 | | SD-0790361-SP | . . . Hinge screw | | 膝上げ前テコ段ネジ | 1 |
| 3 | | B3410-051-000 | Knee lifter rear lever | | 膝上げ後テコ | 1 |
| 4 | | SD-0790361-SP | . . . Hinge screw | | 膝上げ後テコ段ネジ | 1 |
| 5 | | B3413-053-000 | Rear lifting bar | | 後ツリ棒 | 1 |
| 6 | | PD-0231100-0B | . . . Cotter pin | | 後ツリ棒割ピン | 1 |
| 7 | | B3414-051-000 | . . . Spring | | 後ツリ棒押シバネ | 1 |
| 8 | | CS-0510713-SC | . . . Spring retaining collar | | 後ツリ棒押バネ受 | 1 |
| 9 | | SS-7110540-SP | . . . Screw | | 後ツリ棒押バネ受止ネジ | 1 |
| 10 | | B3417-051-000 | . . . Roller | | 後ツリ棒コロ | 1 |
| 11 | | SD-0550801-SP | . . . Screw stud | | 後ツリ棒コロ軸 | 1 |
| 12 | | B3416-051-000 | . . . Roller holder | | 後ツリ棒コロ支エ | 1 |
| 13 | | SS-7110510-SP | . . . Screw | | 後ツリ棒コロS止ネジ | 1 |
| 14 | | B1839-520-OA0 | Oil receiving collar, for saddle | | 蓋輪台油溜セット | 1 |
| 15 | | B1841-520-000 | Oil drip felt | | 蓋輪台モルトブレーン | 1 |
| 16 | | B3401-027-OA0 | Knee lifter assembly | | 衝上装置関係(組) | 1 |
| 17 | | B3401-027-000 | Knee lifter base | | ヒザ上げ台 | (1) |
| 18 | | B3402-027-000 | Knee lifting rod bracket | | ヒザ上げ体 | (1) |
| 19 | | B3408-027-000 | . . . Shaft | | ヒザ上げ軸 | (1) |
| 20 | | B3404-027-000 | Spring | | ヒザ上げブラケットバネ | (1) |
| 21 | | B3409-027-000 | Knee lifting rod spring | | ヒザ上げバネ | (1) |
| 22 | | B3407-027-000 | Knee press plate | | ヒザ当板 | (1) |
| 23 | | SM-9081620-SE | . . . Bolt | | ヒザ当板止ネジ | (1) |
| 24 | | NM-6080721-SE | . . . Nut | | ヒザ当板止ネジナット | (1) |
| 25 | | B3403-027-000 | Knee lifter plate rod | | ヒザ当板軸 | (1) |
| 26 | | SS-9201813-CN | . . . Bolt | | ヒザ当板軸角ボルト | (1) |
| 27 | | B3405-027-OA0 | Knee lifting plate | | 衝上ゲ板(組) | (1) |
| 28 | | B3410-027-000 | Knee lifting rod | | 衝上ゲ板軸 | (1) |
| 29 | | SS-9201813-CN | . . . Bolt | | 衝上ゲ板軸角ボルト | (1) |
| 30 | | B3406-027-000 | . . . Bolt | | 衝上ゲ板角ボルト | (1) |
| 31 | | B3411-027-000 | Stopper pin, for base | | ストッパーピン | (1) |
| 32 | | SS-8150710-SN | . . . Screw | | ストッパーピン止ネジ | (1) |
| 33 | | SK-3623200-SC | Knee lifter base screw | | ヒザ上げ装置木ネジ | 3 |
| 34 | | WP-0851216-SC | . . . Washer | | ヒザ上げ装置座金 | 3 |











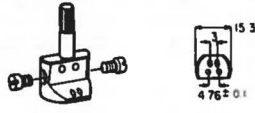

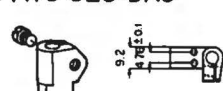

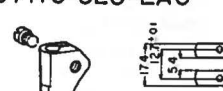
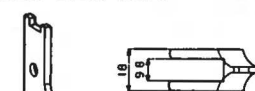
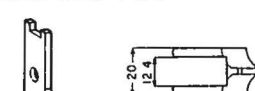
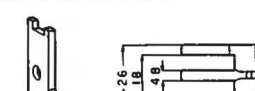

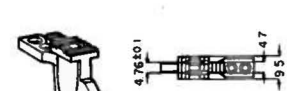

7. EXCHANGING GAUGE PARTS

交換ゲージ部品

$\frac{3}{16}$

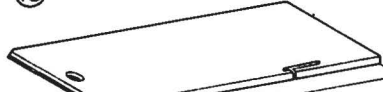
$\frac{1}{4}$

$\frac{1}{2}$

| | | |
|---|---|---|
| <p>① B 1402-520-DAO</p>  | <p>⑨ B 1402-520-FAO</p>  | <p>⑰ B 1402-520-LAO</p>  |
| <p>② B 1470-520-DAO</p>  | <p>⑩ B 1470-520-FAO</p>  | <p>⑱ B 1470-520-LAO</p>  |
| <p>③ B 1525-520-D00</p>  | <p>⑪ B 1525-520-F00</p>  | <p>⑲ B 1525-520-L00</p>  |
| <p>④ B 1109-520-D00</p>  | <p>⑫ B 1109-520-F00</p>  | <p>⑳ B 1109-520-L00</p>  |
| <p>⑤ B 1613-520-D00</p>  | <p>⑬ B 1613-520-F00</p>  | <p>㉑ B 1613-520-L00</p>  |
| <p>⑥ B 1613-520-DOB</p>  | <p>⑭ B 1613-520-FOB</p>  | <p>㉒ B 1613-520-LOB</p>  |
| <p>⑦ B 1112-512-C00</p>  | <p>⑮ B 1112-512-C00</p>  | <p>㉓ B 1112-512-F00</p>  |
| <p>⑧ B 1113-512-C00</p>  | <p>⑯ B 1113-512-C00</p>  | <p>㉔ B 1113-512-F00</p>  |

5/8

3/4

3/8

25 BI402-520-MAO

26 BI470-520-MAO

27 BI525-520-M00

28 BI109-520-M00

29 BI613-520-M00

30 BI613-520-M0B

31 BI112-512-G00

32 BI113-512-G00

33 BI402-520-NAO

34 BI470-520-NAO

35 BI525-520-N00

36 BI109-520-N00

37 BI613-520-N00

38 BI613-520-N0B

39 BI112-512-H00

40 BI113-512-H00

41 BI402-520-KAO

42 BI470-520-KAO

43 BI525-520-K00

44 BI109-520-K00

45 BI613-520-K00

46 BI613-520-K0B

47 BI112-512-E00

48 BI113-512-E00

7. EXCHANGING GAUGE PARTS

交換ゲージ部品

| Ref. No. | Note | Part No. | Description | E.C. | Amt. Req. |
|---|------|---------------|--|---------------------------|-----------|
| | 注記 | 品番 | | 変更年月 | 数量 |
| 3/16" GAUGE PARTS | | | | | |
| 1 | | B1402-520-DA0 | Needle clamp (3/16") | 3/16"用ゲージセット | 1 |
| | | SS-6090410-TP | Needle set screw | 針留(3/16") | 2 |
| 2 | | B1470-520-DA0 | Walking foot (3/16") | 針止ネジ | 1 |
| | | SS-6110710-TP | ... Clamp screw | 押エ中足(3/16") | 1 |
| 3 | | B1525-520-D00 | Presser foot (3/16") | 押エ中足締ネジ | 1 |
| 4 | | B1109-520-D00 | Throat plate (3/16") | 押エ外足(3/16") | 1 |
| 5 | | B1613-520-D00 | Feed dog (3/16") | 針板(3/16") | 1 |
| 6 | | B1613-520-D0B | Feed dog, for 30#, 20# threads (3/16") | 送り(3/16") | 1 |
| 7 | | B1112-512-C00 | Bed slide, left | 送り(丸穴)30#, 20#糸を使用(3/16") | 1 |
| 8 | | B1113-512-C00 | Bed slide, right | 滑り板(左) | 1 |
| | | | | 滑り板(右) | 1 |
| 1/4" GAUGE PARTS | | | | | |
| 9 | | B1402-520-FA0 | Needle clamp (1/4") | 1/4"用ゲージセット | 1 |
| | | SS-6090410-TP | Needle set screw | 針留(1/4") | 2 |
| 10 | | B1470-520-FA0 | Walking foot (1/4") | 針止ネジ | 1 |
| | | SS-6110710-TP | ... Clamp screw | 押エ中足(1/4") | 1 |
| 11 | | B1525-520-F00 | Presser foot (1/4") | 押エ中足締ネジ | 1 |
| 12 | | B1109-520-F00 | Throat plate (1/4") | 押エ外足(1/4") | 1 |
| 13 | | B1613-520-F00 | Feed dog (1/4") | 針板(1/4") | 1 |
| 14 | | B1613-520-F0B | Feed dog, for 30#, 20# threads (1/4") | 送り(1/4") | 1 |
| 15 | | B1112-512-C00 | Bed slide, left | 送り(丸穴)30#, 20#糸を使用(1/4") | 1 |
| 16 | | B1113-512-C00 | Bed slide, right | 滑り板(左) | 1 |
| | | | | 滑り板(右) | 1 |
| 1/2" GAUGE PARTS (Manufactured on order) | | | | | |
| 17 | | B1402-520-LA0 | Needle clamp (1/2") | 1/2"用ゲージセット(受注生産) | 1 |
| | | SS-6090410-TP | Needle set screw | 針留(1/2") | 2 |
| 18 | | B1470-520-LA0 | Walking foot (1/2") | 針止ネジ | 1 |
| | | SS-6110710-TP | ... Clamp screw | 押エ中足(1/2") | 1 |
| 19 | | B1525-520-L00 | Presser foot (1/2") | 押エ中足締ネジ | 1 |
| 20 | | B1109-520-L00 | Throat plate (1/2") | 押エ外足(1/2") | 1 |
| 21 | | B1613-520-L00 | Feed dog (1/2") | 針板(1/2") | 1 |
| 22 | | B1613-520-L0B | Feed dog, for 30#, 20# threads (1/2") | 送り(1/2") | 1 |
| 23 | | B1112-512-F00 | Bed slide, left | 送り(丸穴)30#, 20#糸を使用(1/2") | 1 |
| 24 | | B1113-512-F00 | Bed slide, right | 滑り板(左) | 1 |
| | | | | 滑り板(右) | 1 |
| 5/8" GAUGE PARTS (Manufactured on order) | | | | | |
| 25 | | B1402-520-MA0 | Needle clamp (5/8") | 5/8"用ゲージセット(受注生産) | 1 |
| | | SS-6090410-TP | Needle set screw | 針留(5/8") | 2 |
| 26 | | B1470-520-MA0 | Walking foot (5/8") | 針止ネジ | 1 |
| | | SS-6110710-TP | ... Clamp screw | 押エ中足(5/8") | 1 |
| 27 | | B1525-520-M00 | Presser foot (5/8") | 押エ中足締ネジ | 1 |
| 28 | | B1109-520-M00 | Throat plate (5/8") | 押エ外足(5/8") | 1 |
| 29 | | B1613-520-M00 | Feed dog (5/8") | 針板(5/8") | 1 |
| 30 | | B1613-520-M0B | Feed dog, for 30#, 20# threads (5/8") | 送り(5/8") | 1 |
| 31 | | B1112-512-G00 | Bed slide, left | 送り(丸穴)30#, 20#糸を使用(5/8") | 1 |
| 32 | | B1113-512-G00 | Bed slide, right | 滑り板(左) | 1 |
| | | | | 滑り板(右) | 1 |
| 3/4" GAUGE PARTS | | | | | |
| 33 | | B1402-520-NA0 | Needle clamp (3/4") | 3/4"用ゲージセット | 1 |
| | | SS-6090410-TP | Needle set screw | 針留(3/4") | 2 |
| 34 | | B1470-520-NA0 | Walking foot (3/4") | 針止ネジ | 1 |
| | | SS-6110710-TP | ... Clamp screw | 押エ中足(3/4") | 1 |
| 35 | | B1525-520-N00 | Presser foot | 押エ中足締ネジ | 1 |
| 36 | | B1109-520-N00 | Throat plate (3/4") | 押エ外足 | 1 |
| 37 | | B1613-520-N00 | Feed dog (3/4") | 針板(3/4") | 1 |
| 38 | | B1613-520-N0B | Feed dog, for 30#, 20# threads (3/4") | 送り(3/4") | 1 |
| 39 | | B1112-512-H00 | Bed slide, left | 送り(丸穴)30#, 20#糸を使用(3/4") | 1 |
| 40 | | B1113-512-H00 | Bed slide, right | 滑り板(左) | 1 |
| | | | | 滑り板(右) | 1 |
| 3/8" GAUGE PARTS | | | | | |
| 41 | | B1402-520-KA0 | Needle clamp (3/8") (standard) | 3/8"用ゲージセット(標準) | 1 |
| | | SS-6090410-TP | Needle set screw | 針留(3/8") | 2 |
| 42 | | B1470-520-KA0 | Walking foot (3/8") | 針止ネジ | 1 |
| | | SS-6110710-TP | ... Clamp screw | 押エ中足(3/8") | 1 |
| 43 | | B1525-520-K00 | Presser foot (3/8") | 押エ中足締ネジ | 1 |
| 44 | | B1109-520-K00 | Throat plate (3/8") | 押エ外足(3/8") | 1 |
| 45 | | B1613-520-K00 | Feed dog (3/8") | 針板(3/8") | 1 |
| 46 | | B1613-520-K0B | Feed dog, for 30#, 20# threads (3/8") | 送り(3/8") | 1 |
| 47 | | B1112-512-E00 | Bed slide, left | 送り(丸穴)30#, 20#糸を使用(3/8") | 1 |
| 48 | | B1113-512-E00 | Bed slide, right | 滑り板(左) | 1 |
| | | | | 滑り板(右) | 1 |

[注] 標準品以外は受注生産品ですから、別途御注文下さい。

(Note) All parts other than standard parts are special order parts at extra cost so please order them separately.

| Part No. 品番 | Page 頁 | Item 項目 | Ref. No. | Part No. 品番 | Page 頁 | Item 項目 | Ref. No. |
|----------------|-----------|------------|-------------|----------------|-----------|------------|-------------|
| NS-6160520-SP | 6 | 3 | 15 | SS-7111310-SP | 8 | 4 | 15 |
| NS-6620310-SP | 6 | 3 | 18 | SS-7151120-SP | 4 | 2 | 7 |
| NS-6660430-SP | 8 | 4 | 37 | SS-7160740-SP | 2 | 1 | 29 |
| NS-6680480-SP | 6 | 3 | 48 | SS-7161640-SP | 8 | 4 | 34 |
| NS-6700420-SP | 6 | 3 | 24 | SS-7681750-TP | 4 | 2 | 15 |
| | | | | SS-7681750-TP | 4 | 2 | 39 |
| SNAP RING | Eリング | | | SS-7762840-SP | 10 | 5 | 17 |
| RE-0500000-KO | 6 | 3 | 58 | SS-8081450-SP | 6 | 3 | 30 |
| | | | | SS-8090530-TP | 10 | 5 | 10 |
| TAPER PIN | テーパーステン | | | SS-8090710-SP | 4 | 2 | 55 |
| PD-0231100-0B | 12 | 6 | 6 | SS-8110510-SP | 2 | 1 | 27 |
| PS-0200102-KH | 4 | 2 | 59 | SS-8110510-SP | 6 | 3 | 53 |
| PT-0201200-SO | 8 | 4 | 17 | SS-8110510-SP | 6 | 3 | 34 |
| PT-0301600-SO | 6 | 3 | 70 | SS-8110750-SP | 6 | 3 | 54 |
| | | | | SS-8111251-SP | 2 | 1 | 54 |
| HINGE SCREW | 段ネジ | | | SS-8150410-SP | 6 | 3 | 41 |
| SD-0470281-SP | 2 | 1 | 47 | SS-8150580-SP | 10 | 5 | 50 |
| SD-0550801-SP | 12 | 6 | 11 | SS-8150710-SP | 4 | 2 | 30 |
| SD-0630241-SD | 2 | 1 | 34 | SS-8150710-SP | 10 | 5 | 23 |
| SD-0640322-TP | 4 | 2 | 54 | SS-8150710-SN | 12 | 6 | 32 |
| SD-0640322-TP | 4 | 2 | 52 | SS-8150750-SP | 10 | 5 | 12 |
| SD-0790361-SP | 12 | 6 | 2 | SS-8151150-SP | 6 | 3 | 37 |
| SD-0790361-SP | 12 | 6 | 4 | SS-8151150-SP | 8 | 4 | 2 |
| SD-0790801-SP | 6 | 3 | 14 | SS-8151150-SP | 8 | 4 | 5 |
| SD-0800481-SP | 8 | 4 | 18 | SS-8151150-SP | 10 | 5 | 21 |
| SD-0801601-SP | 8 | 4 | 20 | SS-8151160-SP | 6 | 3 | 7 |
| SD-0950801-SP | 6 | 3 | 23 | SS-8151230-SP | 4 | 2 | 36 |
| | | | | SS-8151230-SP | 10 | 5 | 37 |
| SCREW | ネジ | | | SS-8151350-SP | 4 | 2 | 31 |
| SK-3623200-SC | 12 | 6 | 33 | SS-8151350-SP | 4 | 2 | 20 |
| SM-9081620-SE | 12 | 6 | 23 | SS-8151550-SP | 10 | 5 | 52 |
| SS-2090710-SP | 2 | 1 | 10 | SS-8151770-SP | 6 | 3 | 61 |
| SS-2090710-SP | 2 | 1 | 12 | SS-8151780-SP | 4 | 2 | 45 |
| SS-2090710-SP | 2 | 1 | 14 | SS-8151780-SP | 4 | 2 | 63 |
| SS-2110920-TP | 2 | 1 | 22 | SS-8151780-SP | 6 | 3 | 62 |
| SS-3090610-SP | 2 | 1 | 5 | SS-8152030-SP | 4 | 2 | 46 |
| SS-6080610-TP | 6 | 3 | 69 | SS-8152030-SP | 6 | 3 | 39 |
| SS-6080720-SP | 6 | 3 | 29 | SS-8152030-SP | 10 | 5 | 3 |
| SS-6080810-SP | 2 | 1 | 53 | SS-8152030-SP | 10 | 5 | 11 |
| SS-6090410-TP | 6 | 3 | 27 | SS-8152080-SP | 4 | 2 | 64 |
| SS-6090410-TP | 15 | 7 | 1 | SS-8660530-TP | 4 | 2 | 33 |
| SS-6090410-TP | 15 | 7 | 9 | SS-8660530-TP | 10 | 5 | 44 |
| SS-6090410-TP | 15 | 7 | 17 | SS-8660670-SP | 10 | 5 | 45 |
| SS-6090410-TP | 15 | 7 | 25 | SS-8660810-TP | 10 | 5 | 42 |
| SS-6090410-TP | 15 | 7 | 33 | SS-8660970-TP | 4 | 2 | 34 |
| SS-6090410-TP | 15 | 7 | 41 | SS-8660970-TP | 10 | 5 | 41 |
| SS-6090620-SP | 10 | 5 | 29 | SS-8680540-SP | 4 | 2 | 10 |
| SS-6090630-SP | 2 | 1 | 23 | SS-8680730-SP | 4 | 2 | 11 |
| SS-6090910-TP | 8 | 4 | 22 | SS-8681650-TP | 4 | 2 | 14 |
| SS-6110610-TP | 10 | 5 | 26 | SS-8681650-TP | 4 | 2 | 38 |
| SS-6110710-TP | 8 | 4 | 30 | SS-9111010-SP | 2 | 1 | 7 |
| SS-6110710-TP | 15 | 7 | 2 | SS-9201813-CN | 12 | 6 | 26 |
| SS-6110710-TP | 15 | 7 | 10 | SS-9201813-CN | 12 | 6 | 29 |
| SS-6110710-TP | 15 | 7 | 18 | | | | |
| SS-6110710-TP | 15 | 7 | 26 | WASHER | 座金 | | |
| SS-6110710-TP | 15 | 7 | 34 | WP-0371016-SD | 10 | 5 | 30 |
| SS-6110710-TP | 15 | 7 | 42 | WP-0480856-SP | 2 | 1 | 8 |
| SS-6111140-SP | 8 | 4 | 47 | WP-0851216-SC | 12 | 6 | 34 |
| SS-6111210-SP | 6 | 3 | 46 | | | | |
| SS-6151440-SP | 6 | 3 | 13 | | | | |
| SS-6151920-SP | 6 | 3 | 22 | | | | |
| SS-6153040-SP | 10 | 5 | 19 | | | | |
| SS-7090520-SP | 2 | 1 | 56 | | | | |
| SS-7090520-SP | 10 | 5 | 14 | | | | |
| SS-7090910-SP | 6 | 3 | 3 | | | | |
| SS-7090910-SP | 8 | 4 | 8 | | | | |
| SS-7090910-SP | 8 | 4 | 10 | | | | |
| SS-7110510-SP | 12 | 6 | 13 | | | | |
| SS-7110540-SP | 12 | 6 | 9 | | | | |
| SS-7110720-SP | 2 | 1 | 57 | | | | |

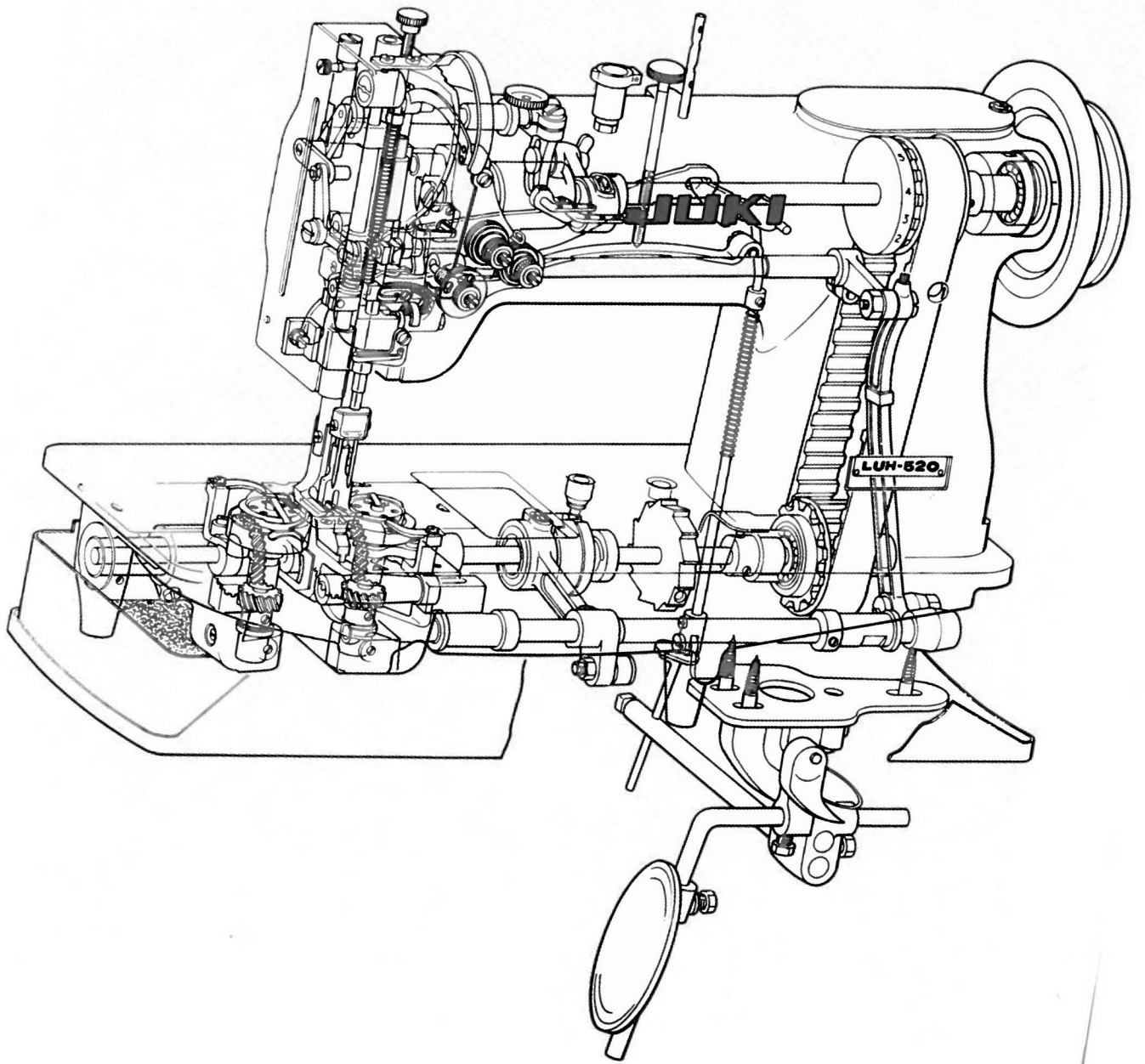

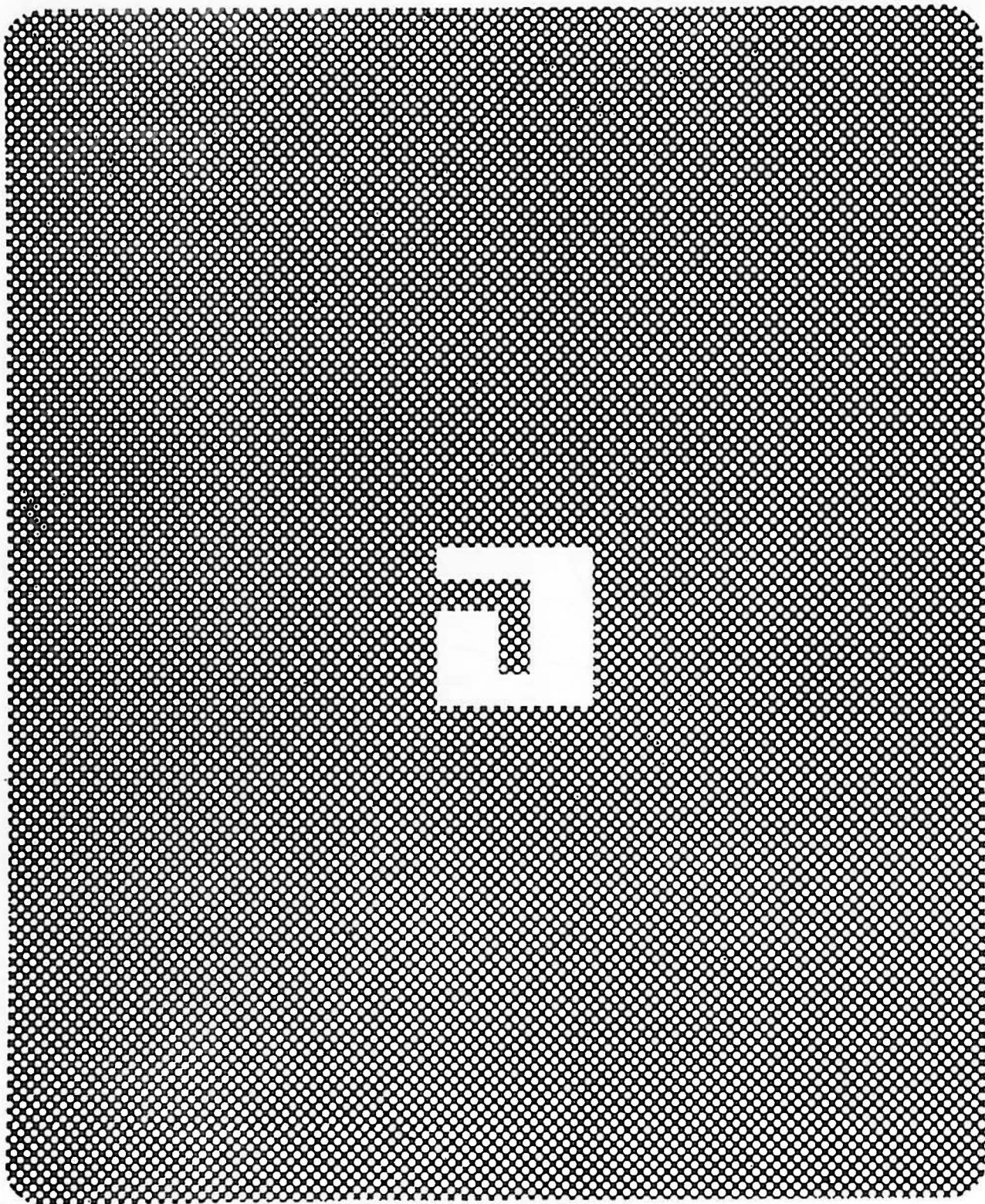

JUKI[®]
TOKYO JUKI INDUSTRIAL CO., LTD.
Business Office : Kabuki-cho, Shinjuku-ku, Tokyo, Japan
Cable Address : JUKI TOKYO
Telex : 22967 JUKITK
Telephone : Tokyo 203-8241

東京重機工業株式会社

営業本部・東京都新宿区歌舞伎町23 TEL.(203)8241(大代)
本社工場・東京都調布市国領町8の2 TEL.(480)1111(大代)

CH520BJEP Printed in Japan(T)